

www.PENNparts.com

Scott's Bait & Tackle

Penn Parts Dept.
945 Radio Road
Tuckerton NJ 08087
(609) 296-1300

No Minimum Order!
Plus, Parts in stock
that Penn doesn't
carry anymore.

SBT Ver. 120211
(based on Penn's Rev 6)

PENN[®]

PARTS LIST FOR MODEL 965

See
Notes

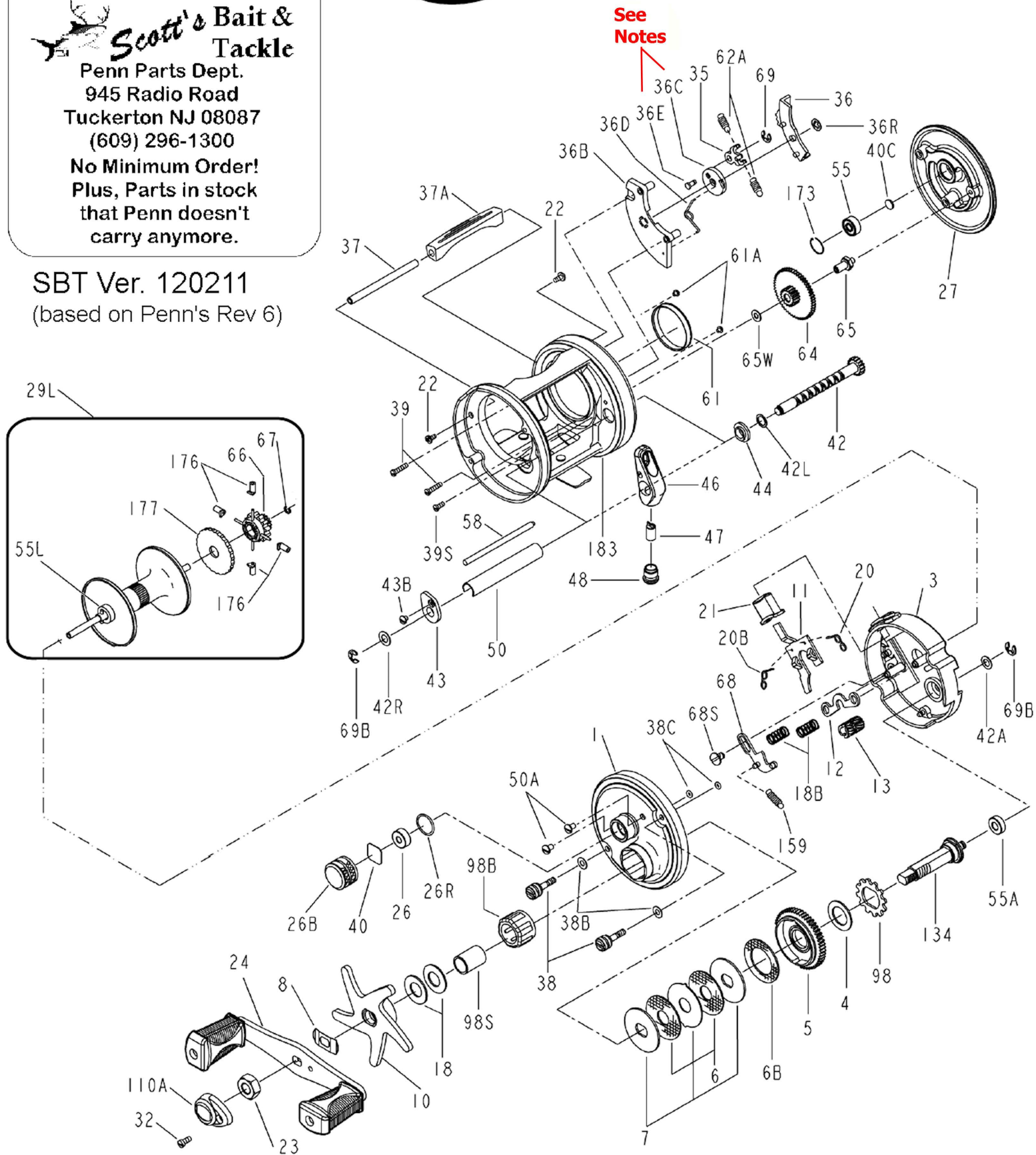

Penn Reel Parts list for:

Model: 965

KEY PART NO NO.	DESCRIPTION	KEY PART NO NO.	DESCRIPTION
3 3-965	INNER R.S. PLATE	40C 40C-310	METAL THRUST WASHER
4 4-155	FIBER WASHER	42A 42R-965	METAL WASHER
5 5N-965	MAIN GEAR	42L 42L-965	L.S. WORM SHAFT WASHER
6 6-965	DRAG WASHER HT-100 (2 REQ.)	42R 42R-965	R.S. WORM SHAFT WASHER
6B 6B-965	DRAG WASHER HT-100	43 43-965	R.S. WORM SHAFT BUSHING
7 7C-965	METAL DRAG WASHER (SET OF 3)	43B 43B-965	WORM BUSHING SCREW
8 8-965	STAR TENSION WASHER	44 44-965	L.S. WORM SHAFT BUSHING
10 10-965	STAR DRAG	46 46-975	LINE GUIDE
11 11-965	ECCENTRIC JACK	47 47-975	PAWL
12 12-965	YOKE	48 48-965	PAWL COVER SCREW
13 13N-965	PINION	50 50-965	WORM SHIELD
18 18-965	DISC CLUTCH SPRING (2 REQ.)	50A 50-716	R.S. PLATE SCREW (2 REQ.)
18B 18B-965	YOKE SPRING (2 REQ.)	55 55-113H	BALL BEARING
20 20-965	R.S. JACK SPRING	55A 55A-965	GEAR STUD BUSHING
20B 20B-965	L.S. JACK SPRING	58 58-965	LINE GUIDE POST
21 21-965	CLUTCH RELEASE BUTTON	61 61-965	BRAKE DRUM
22 50-716	POST SCREW (2 REQ.)	61A 43B-965	BRAKE DRUM SCREW (2 REQ.)
23 23-965	HANDLE NUT	62A 62A-965	CLICK SPRING (2 REQ.)
24 24B-965	HANDLE, CHROME (TWO KNOBS)	65 65-965	IDLER GEAR PIN
** 24A-965N	HANDLE, CHROME (SINGLE KNOB)	65W 65W-965	IDLER GEAR WASHER
26 26-965	SPOOL BUSHING	67 67-16S	LOCK RING
26B 26B-965	SPOOL TENSION CAP	68 68-965	SHIFT ARM
26R 26R-965	TENSION CAP 'O' RING	68S 68S-965	SHIFT ARM SCREW
27 27-965	L.S. PLATE	69 69B-50	RETAINING RING (2 EQ.)
29L 29L-965	SPOOL ASSEMBLY	69B 69B-600	RETAINING RING (2 EQ.)
32 32-15	HANDLE CAP SCREW	98 98-965	TRIP RATCHET
35 35-965	CLICK TONGUE	98B 98B-965	ROLLER BEARING
36 36-965	CLICK BUTTON	98S 98S-965	BEARING CLUTCH SHAFT
36B 36B-965	CLICK HOUSING	110A 110A-555	HANDLE NUT CAP
36D 36D-965	CLICK WHEEL SPRING	134 134-965	GEAR STUD
36R 36R-965	RETAINING RING	159 159-965	SHIFT ARM SPRING
37 37-965	THUMB BAR POST	173 173-965	LEFT SIDE BEARING RETAINER
37A 37A-965	THUMB BAR	176 176-965	ANTI-BACKLASH BRAKES (4 REQ.)
39 39-965	L.S. PLATE SCREW (2 REQ.)	177 177-965	BRAKE SELECTION KNOB
39S 39S-965	L.S. PLATE SHORT SCREW	183 183-965	FRAME ASSEMBLY
40 40C-965	METAL THRUST WASHER		

**Gold handles no longer available

NOTE: Many of www.pennparts.com schematics include changes that were either made by Penn, or errors found and corrected by our parts dept.

SBT Ver. 080313 (based on Penn's Rev. 6)

*****Key 55L BEARING ON THE LEFT SIDE OF THE SPOOL:**

Penn did not intend this to be a serviceable part but it can be

replaced if you are very careful. You can tap or pull out the pin and replace the bearing with 55-965 BALL BEARING (SAME AS 55L-965)

BE CAREFUL not to damage the pin in any way – it is not replaceable and you'd end up needing the entire spool.

ORIGINAL:**Early Run: Design change to click wheel sometime between Rev. 0 and Rev. 3**

36C 36C-965 CLICK WHEEL w/2 plastic pins
(2nd Pin tended to sheer off, Replaced by 36E)

36C 36C-965 CLICK WHEEL w/1 plastic pin
36E 36E-965 CLICK TONGUE PIN

ORIGINAL:**Plate/Housing Design change Rev. 6**

1 1-965 RIGHT SIDE PLATE
38 38-965 TAKE-APART SCREW (2 REQ.)
38B 38B-965 SIDE PLATE WASHER
38C 38C-965 SCREW 'O' RING
183 183-965 FRAME ASSEMBLY

1 1N-965 RIGHT SIDE PLATE
38 38N-965 TAKE-APART SCREW (2 REQ.)
38B 38BN-965 SIDE PLATE WASHER
38C 38CN-965 SCREW 'O' RING
183 183-965 FRAME ASSEMBLY

A higher percentage of the reels will have the current plating design. Plates and housing on the newer reels are a darker gold color

The "International 965" is two lines on the early reels, then changed to one line with darker etching on the current ones.

ORIGINAL:**Internal Gear Design change (Diameters are different) (Rev. 6)**

42 42-965 WORM SHAFT
64 64-965 IDLER GEAR
66 66-965 SPOOL GEAR CLICK RATCHET

42 42M-965 WORM SHAFT
64 64M-965 IDLER GEAR
66 66M-965 SPOOL GEAR CLICK RATCHET

TO SEE WHICH TYPE OF GEARS THAT YOU HAVE:

The current 64M-965 is entirely made of plastic, and O.D. measures 1.1 inches. The idler gear is the most distinctive - the 64-965 was a plastic gear with an attached small brass gear, O.D. measures 1.078 inches overall. ALL these gear diameters changed!